

SWITCHED MODE POWER SUPPLY SPECIFICATION

Model Name: EP-2000P10-T3

Revision: A

Date: 2007.06.06

Contents

1. Introduction	4
1.1 Scope.....	4
1.2 General Description.....	4
2. Electrical	4
2.1 AC Input.....	4
2.1.1 Input Over current Protection.....	4
2.1.2 Inrush Current Limiting.....	4
2.1.3 Withstand Voltage.....	5
2.1.4 Catastrophic Failure Protection.....	5
2.2 DC Output.....	5
2.2.1 DC Voltage Regulation.....	5
2.2.2 Output DC Current Ranges.....	6
2.2.3 Out Output Voltage Line Regulation.	6
2.2.4 Cross Regulation.....	7
2.2.5 Efficiency	7
2.2.6 Output Ripple/Noise.....	7
2.2.7 Output Transient Response.....	8
2.2.8 Capacitive Load	8
2.2.9 Closed-loop Stability	8
2.2.10 Power Sequencing.....	8
2.2.11 Voltage Hold-up Time.....	9
2.3 Timing / Housekeeping / Control.....	9
2.3.1 PWR_OK.....	9
2.3.2 PS_ON#.....	10
2.3.3 +5VSB.....	10
2.3.4 Power-on Time.....	10
2.3.5 Rise time.....	10
2.3.6 Overshoot at Turn-on / Turn-off.....	10
2.3.7 Reset after Shutdown.....	10

2.4 Output Protection.....	11
2.4.1 Over voltage Protection.....	11
2.4.2 Over Current Protection.....	11
2.4.3 Short-circuit Protection.....	11
3. Mechanical.....	12
3.1 Physical Dimension.....	12
3.2 AC Connector.	13
3.3 DC Connector Pin Description.....	13
3.4 Fan Control Function (Optional).....	14
4. Environmental.....	14
4.1 Environmental (Operating).....	14
4.2 Environmental (Non-Operating).....	15
5. Electromagnetic Compatibility.....	15
5.1 EMI.....	15
6. Reliability.....	15
6.1 Component Derating.....	15
6.2 Mean Time Between Failures(MTBF).....	16
7. Safety / Agency Approval.....	16

1. Introduction

1.1 Scope

This specification defines the performance and characteristic for the model of TOP-2KW power supply.

1.2 General Description

TOP-2KW is a switching power supply, 2000W self-contained, AC to DC power source supply suitable for mounting in PC, Server Tower and IPC Chassis.

2. Electrical

2.1 AC Input

Table 1 list AC input voltage and frequency requirements for continuous operation. The power supply is capable of supplying full-rated output power over tow input voltage ranges rated 100-132 VAC and 200-240 VAC rms nominal. The correct input range for use in a given environment may be either switch-selectable or auto ranging. The power supply is automatically recovered from AC power loss.

Table 1. AC Input Line Requirements

Parameter	Min.	Nom. ⁽¹⁾	Max.	Unit
Vin (115 VAC)	100	115	132	VACrms
Vin (230VAC)	200	230	240	VACrms
Vin Frequency	47	---	63	VACrms

⁽¹⁾ Nominal voltages for test purposes are considered to be within ± 1.0 V of nominal.

WARNING: THIS POWER SUPPLY CAN DRAW HIGH POWER FROM HOME POWER CIRCUIT. USER NEED TO HOOK UP THE TWO A/C INPUT FROM SEPARATE CIRCUIT BREAKER.

Power Factor Correction (PFC)

TOP-2KW (w/PFC) version is facilitated with the universal input 100VAC ~ 240VAC active PFC with the PF value 0.9~0.99.

2.1.1 Input Over current Protection

The power supply is incorporate primary fusing for input over current protection to prevent damage to the power supply and meet product safety requirements.

2.1.2 Inrush Current Limiting

Maximum inrush current from power-on (with power on at any point on the AC sine) and including, but not limited to, three line cycles, shall be limited to a level below the surge rating of the input line cord, AC switch if present, bridge rectifier, fuse, and EMI filter components. Repetitive ON/OFF cycling of the AC input voltage should not damage the power supply or cause the input fuse to blow.

2.1.3 Withstand Voltage

The power supply is capable of withstanding a maximum 2200 VDC potential between the input and ground for a period of 1 minute.

2.1.4 Catastrophic Failure Protection

If a component failure occurs, the power supply will not exhibit any of the following:

- * Flame
- * Excessive smoke
- * Charred PCB
- * Fused PCB conductor
- * Startling noise
- * Emission of molten material

2.2 DC Output

2.2.1 DC Voltage Regulation

The DC output voltages are remain within the regulation ranges shown in Table 2 when measured at the load end of the output connectors under all line, Load, and environmental conditions.

Table 2. DC Input Line Requirements

Output	Range	Min.	Nom.(1)	Max.	Unit
+12VDC ⁽¹⁾ (V1,V2,V3,V4,V5,V6,V7)	± 5%	+11.40	+12.00	+12.60	Volts
+5VDC	± 5%	+4.75	+5.00	+5.25	Volts
+3.3VDC	± 5%	+3.14	+3.30	+3.47	Volts
-12VDC	± 10%	-10.80	-12.00	-13.20	Volts
+5VSB	± 5%	+4.75	+5.00	+5.25	Volts

(1) ATX +12VDC peak loading, regulation at the + 12Vdc output can go to±10%.

2.2.2 Output DC Current Ranges

All outputs are within the specified limits of regulation when each output is subjected to the conditions listed below.

Table 3. DC Input Line Requirements

Parameter	Min.	Max.		Unit
+5V	0.3	28		A
+12V1	0.5	20	60 144 84	A
+12V2	0.5	20		A
+12V3	0.5	20		A
+12V4	0	22		A
+12V5	0	22		A
+12V6	0.	22		A
+12V7	0	22		A
+3.3V	0.3	28		A
-12V	0.1	0.8		A
+5Vsb	0.1	7.0		A

- Notes:(1) The maximum continuous total DC outputs power shall not exceed **2000W**.
(2) The maximum continuous load on +5V and +3.3V outputs shall not exceed **200W**.
(3) The maximum combined current for the +12V output is 144A for TOP-2KW.
(4) The maximum continuous load on +12V, +5V and 3.3V outputs have not exceeded **1960W**.
(5) Peak current is limited to total duration of 10 seconds from the instance of PWROK driven true. The power supply is able to sustain maximum current for an unlimited after these initial 10 seconds.

2.2.3 Output Voltage Line Regulation

The following table specifies line regulation as measured from minimum to maximum load including the transient response requirements as detailed in this document.

Table 4. DC Output Tolerance Specifications

DC Nominal Output	Output Voltage Tolerance
+12 VDC (V1,V2,V3,V4,V5,V6,V7)	±1%
+5 VDC	±1%
+3.3 VDC	±1%
-12 VDC	±2%
+5 VSB	±1%

2.2.4 Cross Regulation

The power supply DC outputs perform within all line and load specifications Regardless of the static or transient loads on any of the outputs.

2.2.5 Efficiency

75% minimum at 230VAC, 2000W output.

2.2.6 Output Ripple/Noise

The output ripple/noise requirements listed in Table 5 should be met throughout the load ranges specified and under all input voltage conditions as specified. Ripple and noise are defined as periodic or random signals over a frequency band of 10 Hz to 20MHz. Measurements shall be made with an oscilloscope with 20 MHz bandwidth. Outputs should be bypassed at the connector with a 0.1 μ F ceramic disk capacitor and a 10 μ F electrolytic capacitor to simulate system loading. See Figure1.

Table 5. DC Output Ripple/Noise

Output	Max. Ripple (mVpp)	Noise (mVpp)
+12 VDC (V1,V2,V3,V4,V5,V6,V7)	120	240
+5 VDC	50	100
+3.3 VDC	50	100
-12 VDC	120	240
+5 VSB	50	100

Figure1. Differential Noise Test Setup

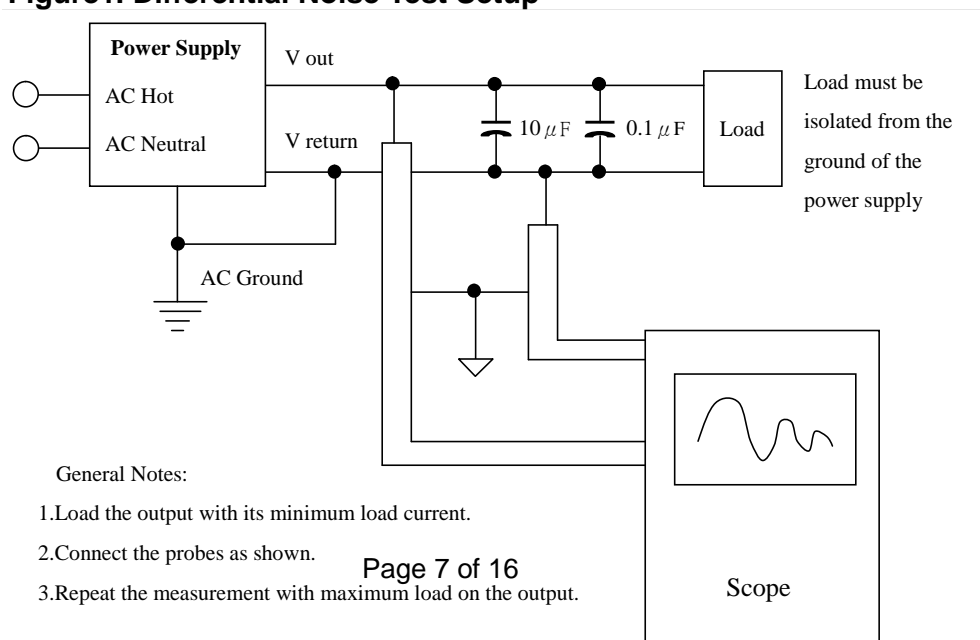

2.2.7 Output Transient Response

Table 6 summarizes the expected output transient step sizes for each output. The transient load slew rate is = $1.0A/\mu s$.

Table 6. DC Output Ripple/Noise

Output	Max. step size (% of rated output amps) ⁽¹⁾	Max. step size (amps)	Output voltage (Tolerance)
+12 VDC (V1,V2,V3,V4,V5,V6,V7)	50%	-	± 5%
+5 VDC	30%	-	± 5%
+3.3 VDC	30%	-	± 5%
-12 VDC	-	0.1A	± 10%
+5 VSB	-	0.1A	± 5%

⁽¹⁾ For example, for a rated +5 VDC output of 28 A, the transient step would be $30\% * 28A = 8.4A$.

2.2.8 Capacitive Load

The power supply is able to power up and operate normally with the following capacitances simultaneously present on the DC outputs.

Table 7. Output Capacitive Loads

Output	ATX12V Capacitive load (μF)
+12 VDC (V1,V2,V3,V4,V5,V6,V7)	20,000
+5 VDC	10,000
+3.3 VDC	6,000
-12 VDC	350
+5 VSB	350

2.2.9 Closed-loop Stability

The power supply is unconditionally stable under all line/load/transient loads Conditions including capacitive loads specified in Table 7. A minimum of 45 degrees phase margin and 10 dB gain margin is recommended at both the maximum and minimum loads.

2.2.10 Power Sequencing

All outputs, regardless of loading, turn on within 50ms of each other.
The +5VSB output is in regulation for a minimum of 10ms prior to the other output rails reaching regulation.

2.2.11 Voltage Hold-up Time

The power supply would maintain output regulation despite a loss of input power at the low-end nominal range-115VAC/60Hz or 230 VAC/50Hz-at Maximum continuous output load as applicable for a minimum of 16 ms.

2.3 Timing / Housekeeping / Control

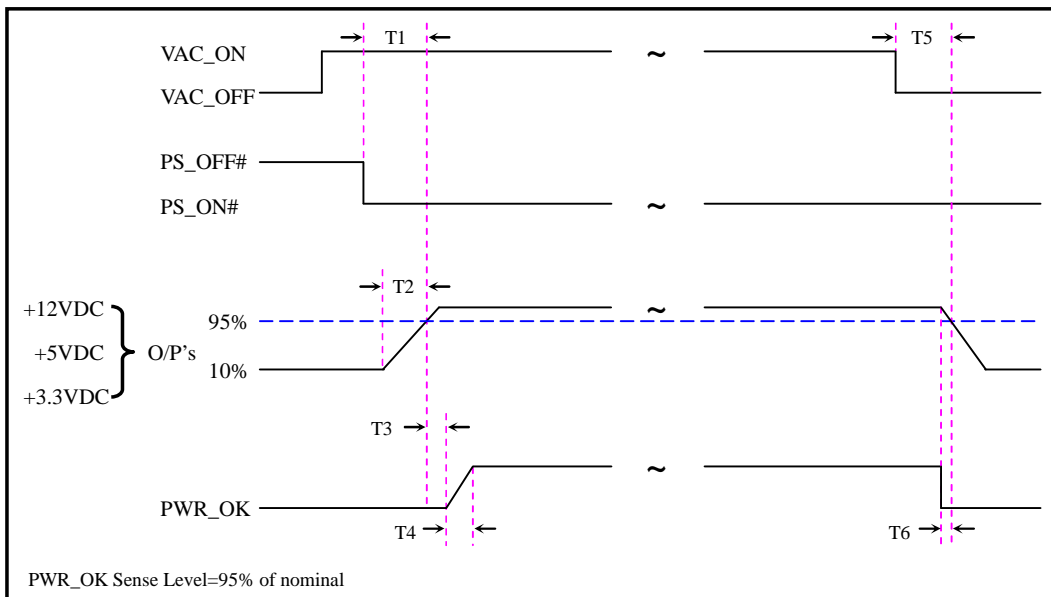

Figure 2. Power Supply Timing

$T1 < 100\text{ms}$	T1 : Power-on Time
$0.1\text{ms} \leq T2 \leq 25\text{ms}$	T2 : Rise Time
$100\text{ms} < T3 < 500\text{ms}$	T3 : PWR_OK Delay
$T4 \leq 10\text{ms}$	T4 : PWR_OK Rise time
$T5 \geq 16\text{ms}$	T5 : AC Loss to PWR_OK Hold-up Time
$T6 \geq 1\text{ms}$	T6 : Power-down Warning

2.3.1 PWR_OK

The power supply accepts a logic collector level, which will disable/enable all the output voltages. As the logic level is low, output voltages are enabling, as the logic level is high, output voltages are disabling. The definition of logic low/high level is as:

High Level: 2.50V ~ 5.25V while sourcing 0.4mA maximum
 Low Level: 0.0V ~ 0.50V while sinking 5.0mA maximum
 Rise Time: 3.0ms maximum (10.0% ~ 90.0%)

2.3.2 PS_ON#

The power supply provides an internal pull-up to TTL high. The power supply also provides denounce circuitry on PS_ON# to prevent it from oscillating on/off at startup when activated by a mechanical switch. The DC output enable circuitry is SELV-complaint.

Table 8. PS_ON# Signal Characteristics

	Min.	Max.
V _{IL} , Input Low Voltage	0.0V	0.8V
V _{IL} , Input Low Current (V _{in} = 0.4 V)		-1.6mA
V _{IH} , Input High Voltage (I _{in} = -200 μA)	2.0V	
V _{IH} , open circuit, I _{in} = 0		5.25V

2.3.3 +5VSB

The +5VSB is capable of delivering a maximum of 2.0A at +5V ±5% to external circuit. The power supply +5VSB is with over current protection.

2.3.4 Power-on Time

The power-on time is less than 100ms (T₁ < 100ms). The +5VSB has a power-on time of two seconds maximum after application of valid AC voltages. (Figure 1)

2.3.5 Rise time

The output voltages rise from ≤ 10% of nominal to within the regulation ranges within 0.1ms to 25ms (0.1ms ≤ T₂ ≤ 25ms). (Figure 2)

2.3.6 Overshoot at Turn-on / Turn-off

Any overshoot at turn on or turn off is under 10% of the nominal DC output voltage with further stipulation that all DC outputs are within their specified DC voltage ranges before the generation of the power good signal. Additionally, no voltage may undershoot or overshoot once the power good signal has been asserted.

2.3.7 Reset after Shutdown

The power supply latches into a shutdown state because of a fault condition on its outputs, the power supply returns to normal operating after the fault has been removed and the PS_ON# (or AC input) has been cycled OFF/ON with a

minimum OFF time of 1 second.

2.4 Output Protection

Each DC output is protected from over voltage, over current and short circuit. The following sections include the details for these protection mechanisms.

2.4.1 Over voltage Protection

The over voltage sense circuitry and reference shall reside in packages that are Separate and distinct from the regulator control circuitry and reference. No single point fault is able to cause a sustained over voltage condition on any or all outputs. The power supply provides latch-mode over voltage protection as defined in Table 9.

Table 9. Over voltage Protection

Output	Min.	Nom.	Max.	Unit.
+12 VDC (V1,V2,V3,V4,V5,V6,V7)	13.4	15.0	15.6	Volts
+5 VDC	5.74	6.3	7.0	Volts
+3.3 VDC	3.76	4.2	4.3	Volts

2.4.2 Over Current Protection

The power supply DC outputs are protected from supplying output current above the maximum ratings defined in Table 1, and when output power is between 110%~150%. With the exception of the 5VSB output, all DC outputs are latched off in the event of an over-current event on any of the DC outputs. In the event of a short circuit on any output, except the 5VSB rail, all outputs are disabled and remain disabled until the power supply is powered off back on. The 5VSB rail will recover upon removal of the over current condition.

2.4.3 Short-circuit Protection

The power supply DC outputs are protected from damage due to faults, when any output shorts to ground. In the event of a short circuit on any output, all outputs shall be disabled and remain disabling until the power supply is powered off and back on. The 5VSB rail will recover upon removal of the over current condition.

3. Mechanical

3.1 Physical Dimension

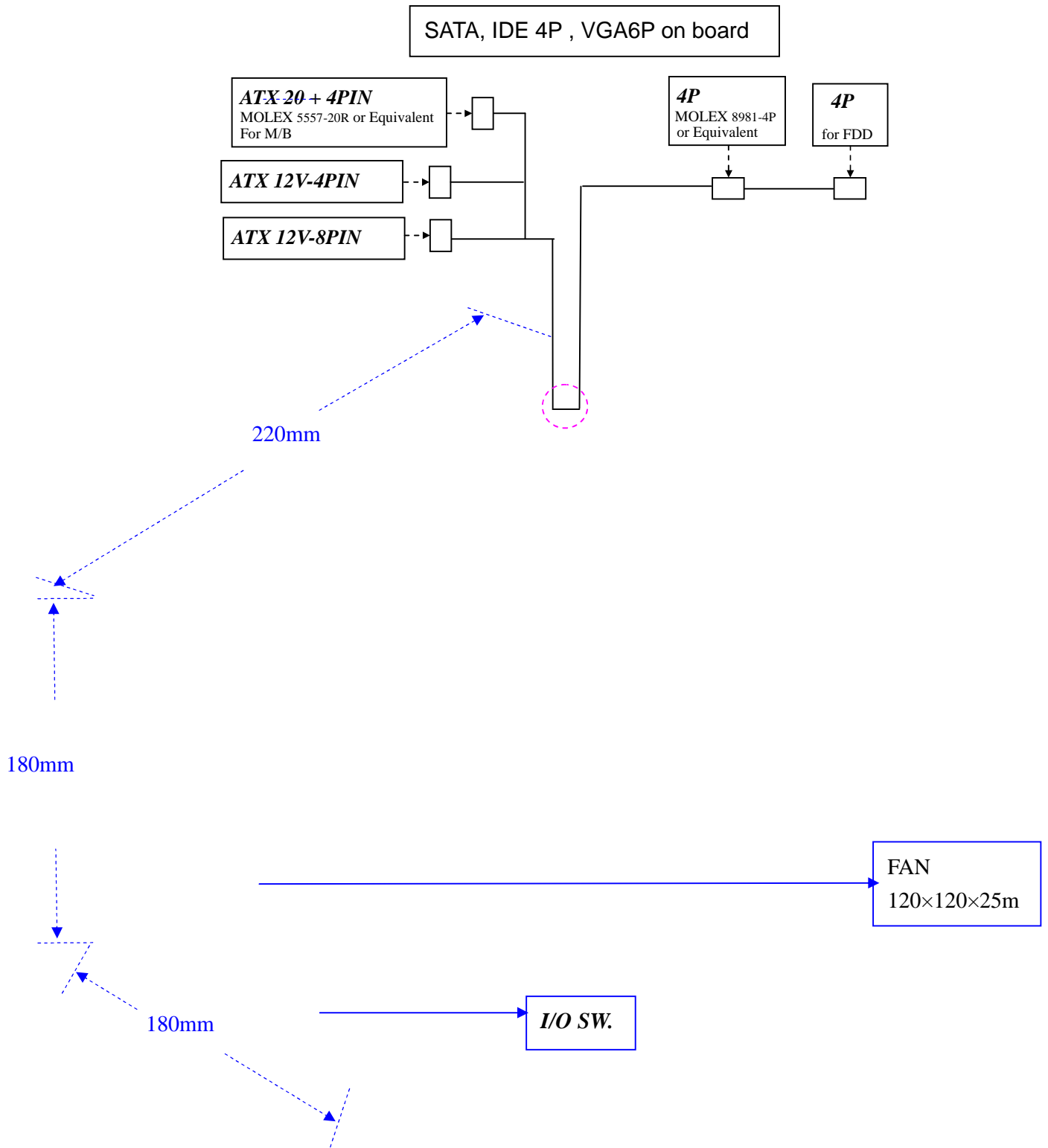

3.2 AC Connector

The AC input receptacle is an IEC 320 type or equivalent. In lieu of a dedicated switch, the IEC 320 receptacle may be considered the mains disconnect.

3.3 DC Connector Pin Description

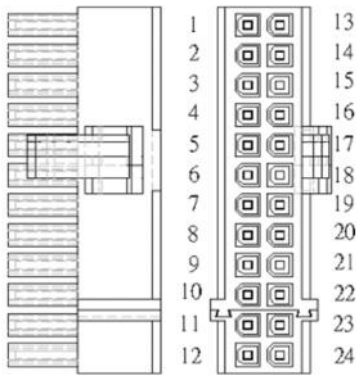

Pin	Color	Signal	Pin	Color	Signal
1	Orange	+3.3VDC	13	Orange Brown	+3.3VDC +3.3V default sense
2	Orange	+3.3VDC	14	Blue	-12VDC
3	Black	COM	15	Black	COM
4	Red	+5VDC	16	Green	PS_ON/OFF
5	Black	COM	17	Black	COM
6	Red	+5VDC	18	Black	COM
7	Black	COM	19	Black	COM
8	Gray	PWR_ok	20	White	-5VDC
9	Purple	+5VSB	21	Red	+5VDC
10	Yellow	+12VDC	22	Red	+5VDC
11	Yellow	+12VDC	23	Red	+5VDC
12	Orange	+3.3VDC	24	Black	COM

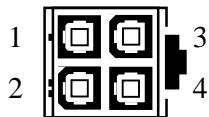

Pin	Color	Signal	Pin	Color	Signal
1	Black	COM	3	Yellow	+12VDC
2	Black	COM	4	Yellow	+12VDC

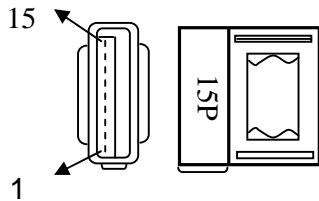

Pin	color	Wire Size	Signal
2	BL	UL1007#18AWG	GND
3	Red	UL1007#18AWG	+5V
4	BL	UL1007#18AWG	GND
5	YL	UL1007#18AWG	+12V

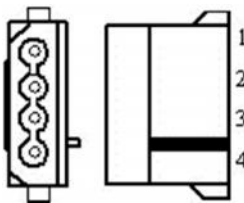

Pin	Color	Signal	Pin	Color	Signal
1	Red	+5VDC	3	Black	COM
2	Black	COM	4	Yellow	+12VDC

20-6P Female	Wire No.	Wire Brown Length
1 【Yellow】	UL1007#16AWG	600 mm
2 【Yellow】	UL1007#16AWG	600 mm
3 【Yellow】	UL1007#16AWG	600mm
4 【Black】	UL1007#16AWG	600 mm
5 【Black】	UL1007#16AWG	600mm
6 【Black】	UL1007#16AWG	600 mm

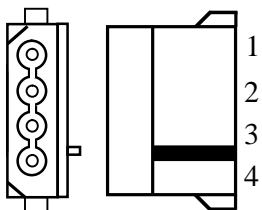

Pin	Color	Signal	Pin	Color	Signal
1	Red	+5VDC	3	Black	COM
2	Black	COM	4	Yellow	+12VDC

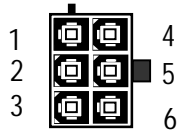

3.4 Fan Control Function (Optional)

In order to prolong the fan's life cycle, the power supply is facilitated with a thermostatic circuitry to monitor the fan speed under the power supply operating temperature.

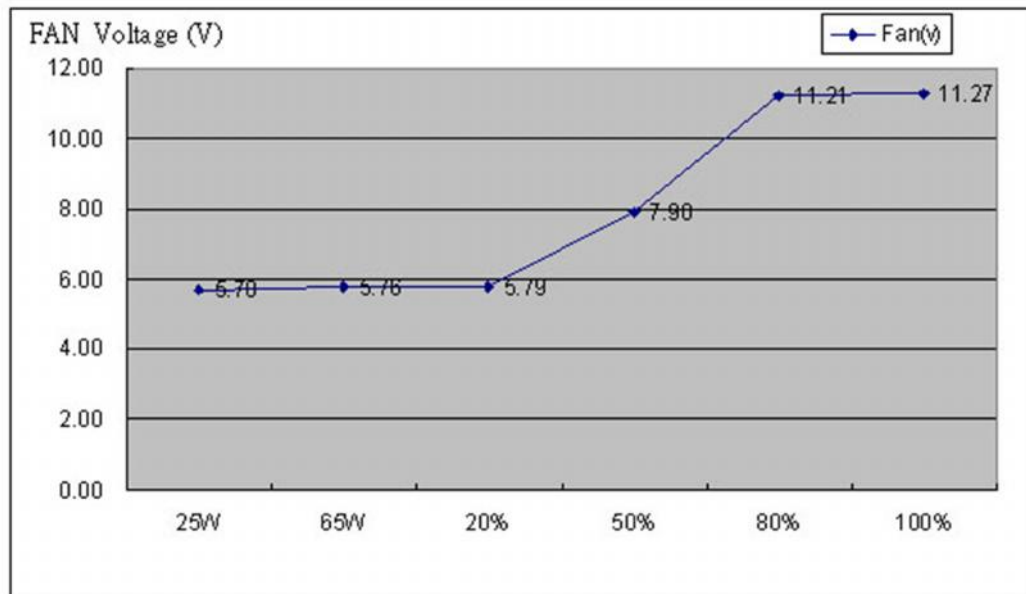

4. Environmental

4.1 Environmental (Operating)

Temperature: 0 C to 50 C

Humidity: 20% to 80% Relative Humidity (non condensing)

Altitude: -61meters to +3,048 meters

Shock: T.B.S.

Vibration: T.B.S.

4.2 Environmental (Non-Operating)

Temperature: -25C to 85C
Humidity: 10% to 90% Relative Humidity (non condensing)
Altitude: -61meters to +15,244 meters
Shock: T.B.S.
Vibration: T.B.S.

5. Electromagnetic Compatibility

The following subsections outline sample product regulations requirements for a typical Power supply. Actual requirements will depend on the design, product end use, target Geography, and other variables. Consult your company's Product Safety and Regulations Department for more details.

5.1 EMI

The power supply is complied with CISPR 22, Class B. Tests are performed at 110VAC 50Hz, 120VAC 60Hz, and 220VAC 50 Hz power. The TOP-1000P9(12U) version meets the requirement of EN 61000-3-2 Class D, and EN 61000-3-3, and the Guidelines for the Suppression of Harmonics in Appliances and General Use Equipment Class D for harmonic line current content at full-rated power.

6. Reliability

6.1 Component Derating

The following component derating guedelines are recommended:

- Semiconductor junction temperatrues shall not exceed 110°C with an ambient of 50°C.
- Inductor case temperature shall not exceed safety agency requirements.
- Capacitor case temperature shall not exceed 95% of rated temperature.
- Component voltage and current derating shall be >10% at 50°C.
- Magnetic saturation of any transformer will not be allowed under any line, load, startup or transient condition including 100% transients on the five main outputs or +5VSB.

6.2 Mean Time Between Failures(MTBF)

The MTBF of the power supply can be calculated with the Part-Stress Analysis method of MIL-HDBK-217F using the quality factors listed in MIL-HDBK-217F. A target calculated MTBF of the power supply is greater than 100,000 hours under the following conditions:

- Full-rated load
- 120 VAC input
- Ground benign
- 25°C ambient

A target calculated MTBF of the power supply is greater than 30,000 hours under the following conditions:

- Full-rated load
- 120 VAC input
- Ground benign
- 50°C ambient

7. Safety / Agency Approval

CUL	1950
TUV	EN60950
CE	EN 61000-3-2/1995, EN 61000-3-3/1995 EN 55024/1998, EN 5022/1994+A1: 1995+A2: 1997
FCC	Part 15, Subpart B, Class B CISPR 22: 1993+A1: 1995+A2: 1996, Class B ANSI C63.4-1992